

## Success with FAIRresponsibility

Grow with Variotherm

Welcome on board 2-3

Wow! New references 4-11

Built for the future 12-13

New products 2013 14

Stay P:UR! 16

"Much too cold for this time of year...!"

...some people were saying just a few weeks ago. "This heat is unbearable," others were moaning just a few days later. By contrast, the customers and partners of Variotherm stayed fresh and relaxed, saying "This perfect room environment is so pleasant!"

As you can see: well-being is at the very heart of our inspiring products and forms the basis for the success of our Variotherm partners. Why does a partnership with Variotherm make sense? This is the key question focused on in this edition of Variotime.

Personally, my answer to this question is based on two fundamental principles: respect and appreciation. For me, it is the daily interaction with some unbelievably fantastic employees, highly motivated suppliers and appreciative partners and customers which propel the Variotherm idea forward.

The last few months in particular have been defined by an intensive development in this regard. The best example of this is the expansion taking place at our forward-thinking company headquarters. Our new products also continue to create a real stir at a national and international level. We are convinced that it is of the utmost importance for all of our products, plans and manufacturing to be in line with our sustainable way of thinking and living.

You can find your own answers over the next few pages. Enjoy!

Best wishes  
Alexander Watzek



# Welcome on board!



Variotherm makes professionals even better!

Take a look with us into the cockpit of the future: we foresee sustainability, environmental awareness, a return to traditional values and a clear way forward. As a Variotherm partner, you can successfully achieve your goal – and stay within the permissible limits too.

During these times in which competition is becoming ever fiercer, construction companies are crowding the market and numerous manufacturers are cutting back on their service offers, achieving the correct market positioning is critical to the future of any installer. One thing is clear: the chance of becoming established on the market with average products and interchangeable services is low. Anyone who settles for mediocrity will go under in this price battle. Expertise, quality, respect and a clear commitment to the environment are reliable factors for success in the long-term.

'Progress through technology' is just a starting point for Variotherm. A friendly approach to customers, suppliers and partners as well as the careful handling of resources are the key guiding principles to success. Variotherm's unique product mix is also based on an enthusiasm for sustainability and protecting the environment. This is appreciated by an increasing number of customers who are specifically searching for ecological yet highly efficient heating and cooling surfaces. For Variotherm partners, this means a chance to appeal to and gain new customers whom you would never have been able to secure by offering standard products alone.

## A partnership with Variotherm makes perfect sense

**Our partners know: we deliver products, services and additional services which impress.**

Variotherm produces quality Austrian goods which are primarily manufactured at our Leobersdorf site. Short distances and sophisticated warehousing logistics allow us to process orders in a very fast and non-bureaucratic manner.

Ordered products are ready for dispatch in just 24 hours. We support partners, building owners and architects with free planning and advice services. For professionals by professionals!

**Advice**  
Honest arguments and appealing products sell best of all. We will provide you with the required expertise to be persuasive and offer your customers optimal advice.

**Planning**  
The Variotherm planning professionals will help you design and plan the perfect system. Comprehensive and free of charge!

**Project development**  
We will support you with every stage of your planning during the project period – and we are always here when you need us!

**Installation training**  
Variotherm products are easy and flexible to install. Your employees can quickly learn how to do this as part of our installation training sessions. Each stage of work will be clearly explained to ensure that you provide your customer with the perfect Variotherm system.

**Hello partner! Call now and become a Variotherm professional!**

**+43 (0) 2256 - 64870 - 0**



And when it comes to searching: as a Variotherm partner, you will be found more easily on the internet!

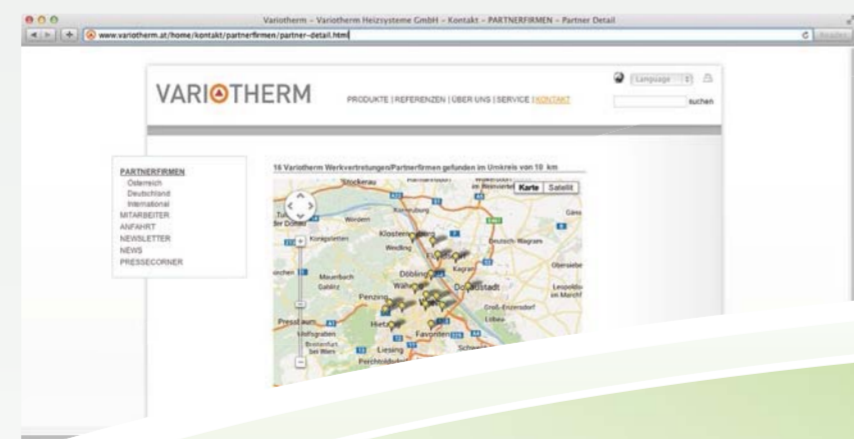

100% comfort

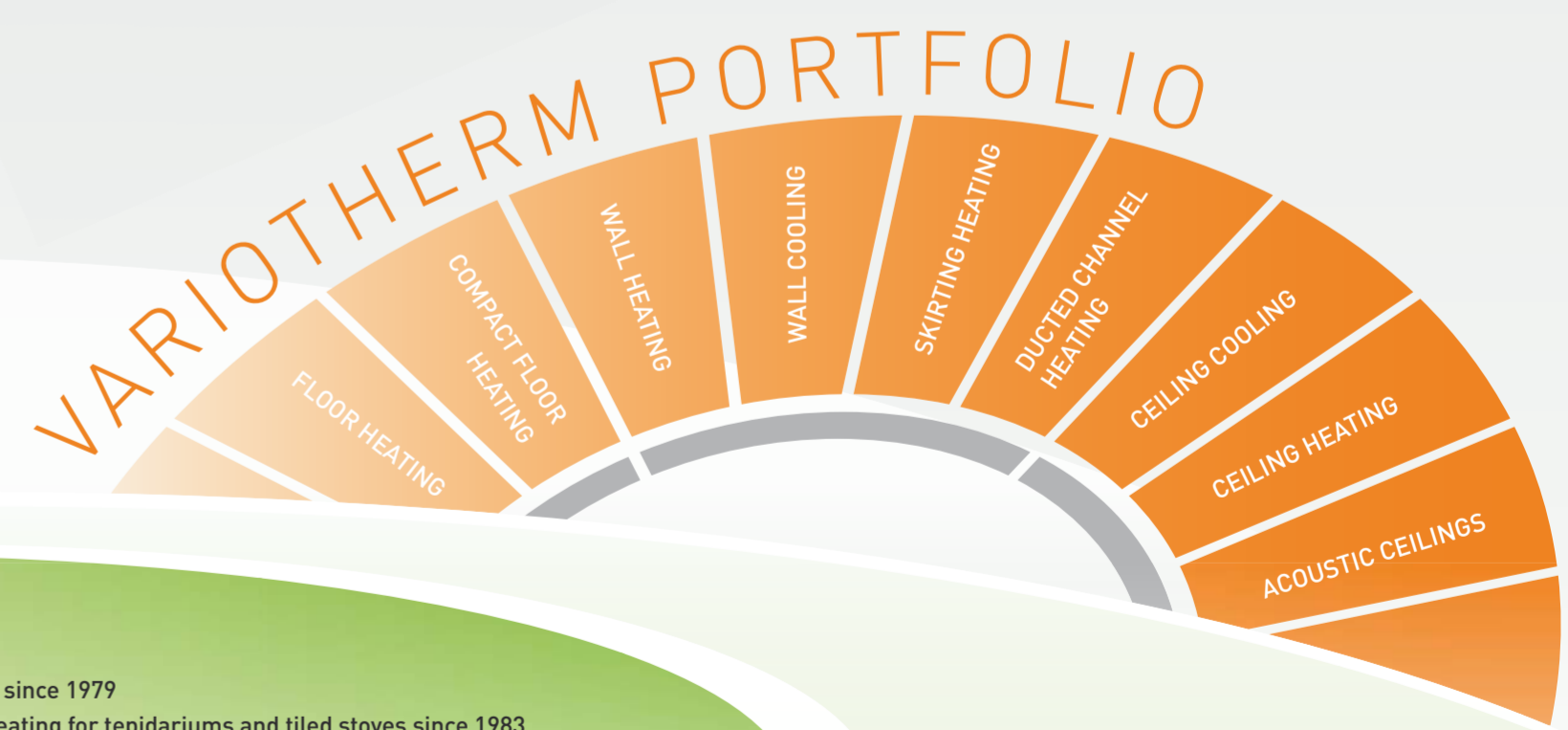
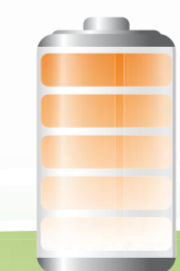

You are in  
**ProfiModus**

- 308.000 m<sup>2</sup> of skirting heating since 1979
- 42.000 m<sup>2</sup> of EasyFlex wall heating for tepidariums and tiled stoves since 1983
- 442.000 m<sup>2</sup> of system wall heating/cooling since 1987
- 700.000 m<sup>2</sup> of floor heating since 1994
- 17.200 m<sup>2</sup> of ducted channel heating since 1997
- 148.000 m<sup>2</sup> of module wall heating/cooling (incl. ceiling cooling/heating) since 1997
- 438.000 m<sup>2</sup> of compact floor heating since 2001



Heating



Cooling



Well-being



Global



Development



Planning



Service



Installation training



ECO



ÖKO



VarioProFile pipe



# Perfection in wine-growing

Andau is known for being the heat centre of Austria due to having the most hours of sunshine and the highest temperature peaks. This is not a PR gimmick for tourists visiting Austria's eastern-most vineyard but rather a guarantee of ripe grapes and a full-bodied and opulent wine-growing culture.

The vineyard operated by the Scheibelhofer family towers is enthroned right here on the elevated and hand-built slopes of the Andreasberg in Andau. With its impressive 40 ha of land in one of the best locations in the region, this is one of the best-known vineyards in Burgenland.

The founder of the operation and a top wine-grower is Johann Scheibelhofer. As an enthusiastic wine-grower, he has created a real stir over the last five years with his white and sweet wines. His most notable masterpiece is the 'Big John' which is highly regarded among wine enthusiasts. The wines produced by his son, Erich Scheibelhofer, are also legendary and multi award-winning.

It is all thanks to the perfectionism of this father-son duo that the sophisticated wines from their vineyard, named the 'Winery of the Year' on numerous occasions, always rank among the winners at various national and international competitions.

The highest standards were also met when the entire vineyard was fitted with floor heating. The strict jury opted for the VarioNop model from Variotherm. The lounge and guesthouse of the Scheibelhofer family were also fitted with the heating system. Guests are encouraged to relax and linger here thanks to the bright colours, light, glass, design and cosy ambience.



## TECHNOLOGY VarioNop floor heating

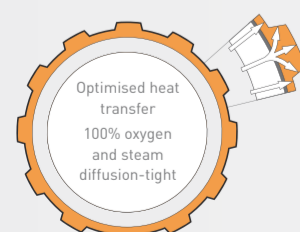
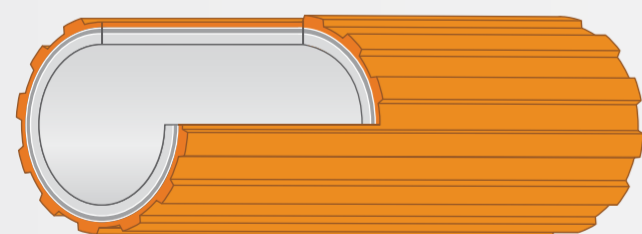

### VarioProFile pipe 16 x 2 Laser

- 5-layer composite pipe
- Only from Variotherm: Interior aluminium laserpipe
- Hence the extremely stable form and yet easy to bend
- Profiled surface!

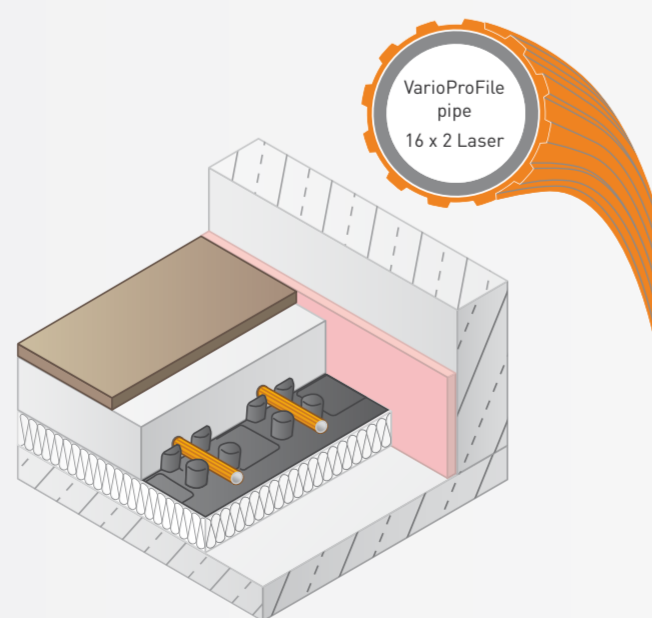

### Weingut Scheibelhofer Andau

Planning and construction management  
Architects Halbritter & Hillerbrand  
AT-7100 Neusiedl am See  
[www.h2arch.at](http://www.h2arch.at)

Installateur  
Installateur-Meisterbetrieb Hermann Koppi  
AT-7143 Apetlon  
[www.koppi.at](http://www.koppi.at)

Variotherm Systems  
330 m<sup>2</sup> VARIONOP FLOOR HEATING





Want to see more?  
See here for our complete picture gallery:  
[www.variotherm.at/tiko](http://www.variotherm.at/tiko)

# Fantastic heating

Dogs and cats feel at home at Europe's most modern animal home. Cold-blooded reptiles and the other little guests at Klagenfurt's centre of expertise for animal welfare visibly enjoy the pleasant radiation energy which has been installed as part of the new floor and wall heating systems.



A few weeks ago, the telephone at the operational headquarters of Klagenfurt's centre of expertise for animal welfare (Tierschutzkompetenzzentrum Klagenfurt) would not stop ringing. An animal transporter had suffered an accident on the Tauern motorway. The victims of the accident: mice, hamsters, rats, snakes, tortoises – a total of 1,700 small animals needed to be saved. The centre sprang into action. But the next danger was quickly apparent. The owner, a Dutch animal dealer, had already commissioned a haulier to recover the animals which had been transported in excessively small containers, with some of the animals having no access to water for up to 14 hours.

"It looked like it would be one of the saddest days in the history of the animal centre. But then everything changed and it became one of the happiest," says Alexander Zuzzi. The team from the animal centre managed to convince the transporters who told their client that they were returning to Holland empty-handed. And so the story had a happy ending. The animal dealer eventually agreed to hand the animals over to the animal centre.

Incidents like this are not isolated cases. It is therefore all the more important that animals which have been subjected to great suffering are handled with care and provided with shelter which offers the optimal space and conditions.

The Klagenfurt competence centre for animal welfare was built with a great deal of passion and offers the ideal conditions for animals. "The right level of heating plays a key role in accommodating animals in a manner appropriate to the species," says Zuzzi. Different animal species need warmer or cooler surfaces. In the animal shelters, half of the area is therefore fitted with floor heating or wall heating in places. This allows the animals to choose whichever they prefer, depending on the weather conditions and their experiences. "Our cats in particular enjoy the soothing radiant heat," says Zuzzi. "They enjoy resting in their hammocks alongside the wall heating – they certainly look very relaxed!"

## TECHNOLOGY VarioRoll floor heating

## SystemWall heating/cooling

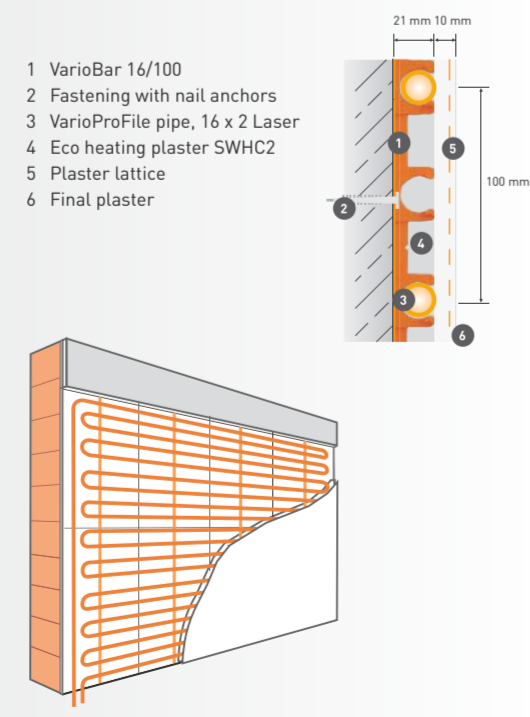
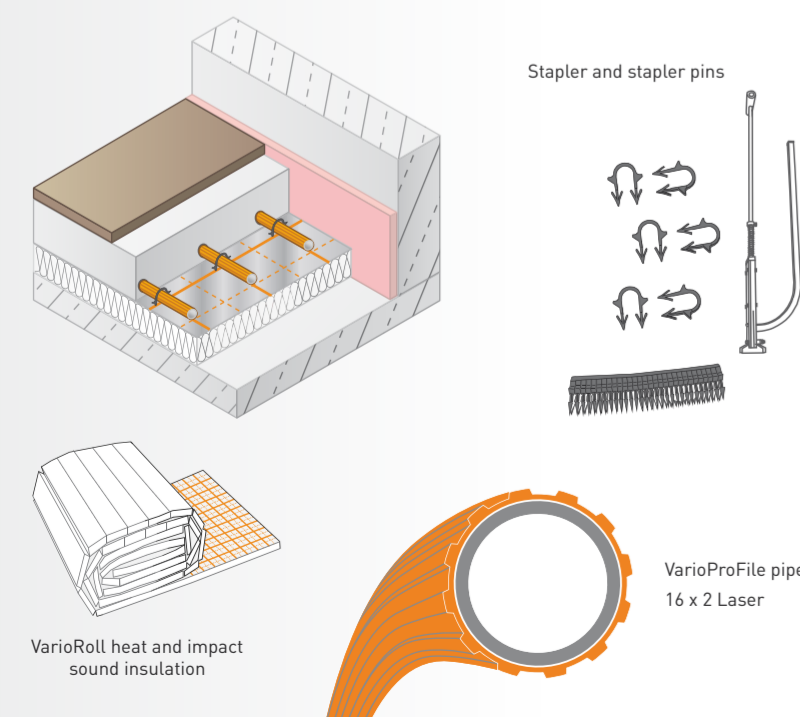

## Tierschutzkompetenzzentrum Klagenfurt

**Construction management**  
Architekt DI Andreas Krainer  
AT-9020 Klagenfurt  
[www.krainerarchitect.at](http://www.krainerarchitect.at)

**Planning**  
TB Ing. Meisslitzer KG  
AT-9020 Klagenfurt  
[www.tbmeisslitzer.com](http://www.tbmeisslitzer.com)

**Installer**  
Feichter Installationen GmbH  
AT-9523 Villach-Landskron  
[www.hf-feichter.at](http://www.hf-feichter.at)

**Variotherm Systems**  
130 m<sup>2</sup> SYSTEM WALL HEATING  
1.240 m<sup>2</sup> VARIOROLL FLOOR HEATING

# Biting the bullet! Extensive systems over a small area

Dr. Daniela Rathpoller has analysed a whole range of shiny new Variotherm products in great detail at her dental practice. Her positive findings: a flawless performance from all of the heating and cooling systems!

Admittedly: despite the substantial focus on retaining a high level of purity, the installation process did require a degree of drilling. However this was only minimal and did not result in much additional expenditure. Dr. Daniela Rathpoller's dental practice now radiates with a new shine throughout.

An all-round solution was installed leaving no wishes unfulfilled in terms of the design of this small space. The module and system wall heating/cooling ensure patient well-being and relaxation. Even patients scared of going to the dentist feel relaxed here. The modular standard ceiling with its classic and acoustic design absorbs most of the sound of the dentist's drill in the treatment room and stops noise escaping outside. Dr. Rathpoller is also renowned for her careful and cautious approach. Nobody gets cold feet at her dental practice – and not just thanks to the pleasant effects of the VarioComp floor heating!

Want to see more?  
See here for our complete picture gallery:  
[www.variotherm.at/rathpoller](http://www.variotherm.at/rathpoller)



## TECHNOLOGY

### ModuleStandardWall

### ModularStandardCeiling-Classic

### ModularStandardCeiling-Acoustic

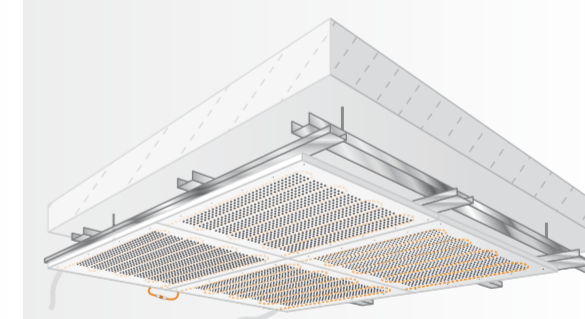
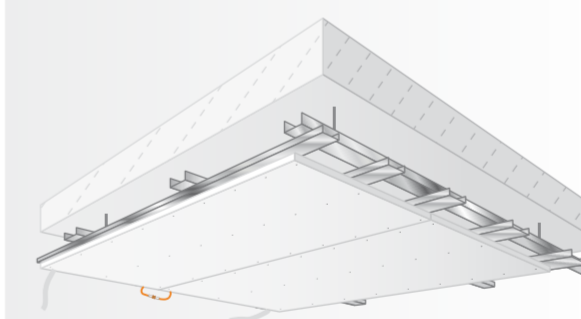
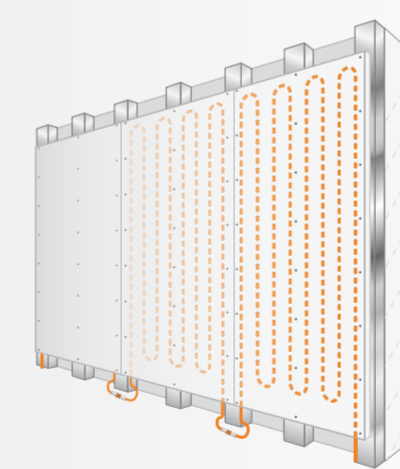

## VarioComp floor heating

## SystemWall heating/cooling

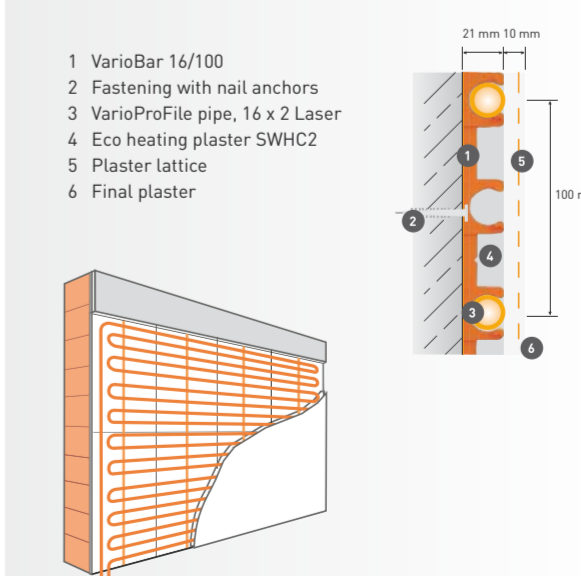
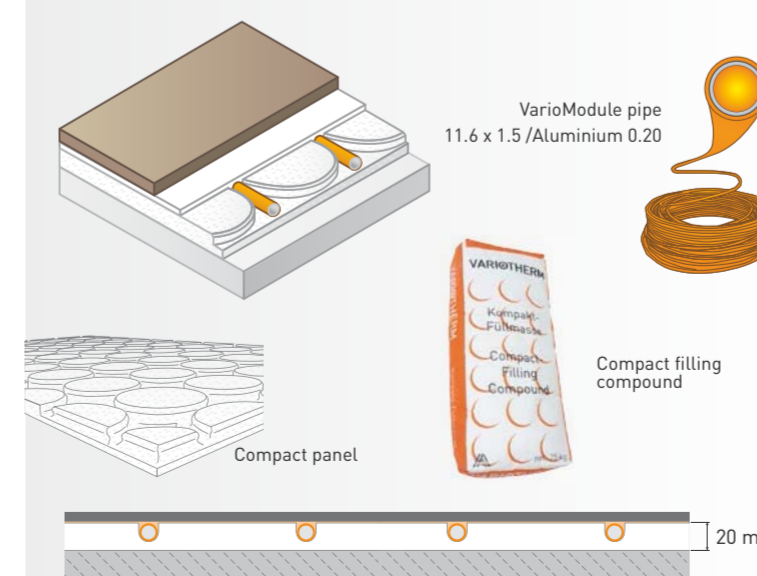

## Zahnarztpraxis Dr. Daniela Rathpoller

**Planning and construction management**  
Architekt DI Martin Bernold  
AT-2700 Wr. Neustadt  
[www.mbarchitects.at](http://www.mbarchitects.at)

**Installer**  
Weghofer GmbH  
AT-7203 Wiesen  
[www.installateur-weghofer.at](http://www.installateur-weghofer.at)

**Variotherm Systems**  
9 m<sup>2</sup> MODULE WALL HEATING/ COOLING  
13 m<sup>2</sup> SYSTEM WALL HEATING/ COOLING  
13 m<sup>2</sup> MODULE STANDARD CEILING - CLASSIC  
10 m<sup>2</sup> MODULE STANDARD CEILING - ACOUSTIC  
65 m<sup>2</sup> VARIOCOMP FLOOR HEATING

# With maturity and character



The origins of pleasure begin in the ground. True flavour unfolds to the full at optimal temperatures. When it comes to wine, this also applies to the vineyard itself. VarioComp floor heating is one of the features present at the Aumann company.

The characterful wines created by the knowledgeable Leo Aumann are the very epitome of the pleasures of this thermal spa region. Compared with the big wines of Burgundy, depending on the variety in question, wines from this vineyard are left to mature in the perfectly air-conditioned barrique cellar. Handed-down expertise and tradition are combined with the latest technology and architecture here.

key contribution to the feeling of well-being – and without it, it would not be possible to open our new building on time,” explains Leo Aumann. “We were under substantial time pressures when building our new vineyard and therefore a normal floor structure with screed would have taken too long”. Thanks to the master builder and installer drawing our attention to the numerous advantages of the super-slim VarioComp floor heating system, we were able to meet our opening deadline in the end.

We also opted for the Variotherm brand for another reason. “Our wines are a top quality gift from nature. In addition to the fact that VarioKomp is a unique product, the heating system impressed us from the outset with its environmental compatibility,” Leo Aumann continues. “This fits with our philosophy – and throughout the company”.

“The floor heating from Variotherm makes a

Want to see more?  
See here for our complete picture gallery:  
[www.variotherm.at/aumann](http://www.variotherm.at/aumann)

## TECHNOLOGY VarioComp floor heating

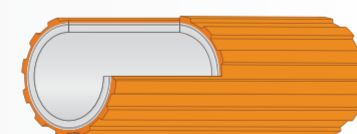
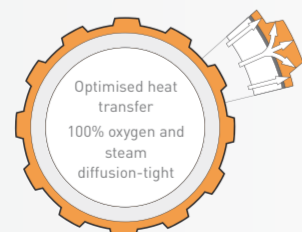
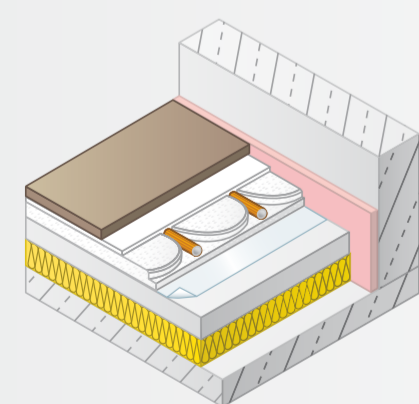

### VarioProFile pipe 16 x 2 Laser

- 5-layer composite pipe
- Only from Variotherm: Interior aluminium laserpipe
- Hence the extremely stable form and yet easy to bend
- Profiled surface!

- VarioKComp
- 1 Substructure
  - 2 Compact panel 600 x 1000mm
  - 3 VarioProFil pipe, 11.6 x 1.5 Laser
  - 4 Compact filling compound
  - 5 Floor covering

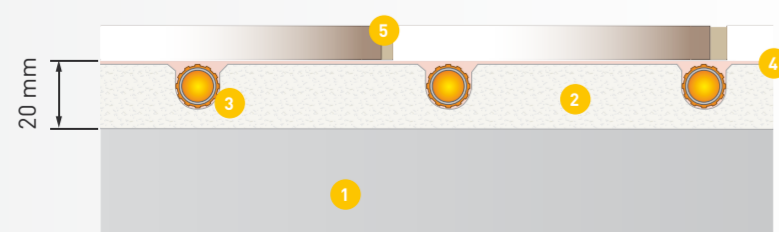

### Weingut Aumann Tribuswinkel

Planning and construction management  
Kloss Bau Ges.m.b.H.  
AT-2514 Traiskirchen  
[www.kloss-bau.at](http://www.kloss-bau.at)

Installer  
1a Installateur - Prewein Installationen GmbH  
AT-2486 Pottendorf  
[www.prewein.co.at](http://www.prewein.co.at)

Variotherm Systems  
360 m<sup>2</sup> VARIOCOMP FLOOR HEATING





Want to see more?  
See here for our complete picture gallery:  
[www.variotherm.at/ames](http://www.variotherm.at/ames)



# Cool cutting-edge technology on approach

Ever stood alongside an aircraft turbine as it starts up? At the AMES aviation centre, it is clear why all of the office and production buildings have been fitted with sound-absorbing acoustic ceilings from Variotherm.

The aviation technology company AMES (Aerospace and Mechanical Engineering Services) represents research and development in the cutting edge technology field. Part of the core business of the centre based in Peggau, Styria involves supplying high-tech construction components to the international aviation industry.

The long list of successfully completed research projects is certainly impressive. And the company has also developed a 16g seat for an interceptor aircraft simulator, a turbo-propelled gas turbine for general aviation and weight reduction for the interiors of VIP flights using new materials and construction processes.

The technical requirements which need to be met when building such a plant are equally complex. "Designing the entire building with sound-absorbing ceiling cooling or heating systems was a key requirement for us," explains AMES Manager Ronald Kräftner. "There were very few suppliers to choose from in this area of application. Variotherm was highly recommended to us by our appointed installations company Fasching from Kindberg. The decision was therefore made very quickly and in the meantime has definitely proven to be the right one!"

Subsequently, all of the areas have been fitted with the ModuleStandardCeiling-Classic or the ModuleStandardCeiling-Acoustic, as required. VarioRoll floor heating guarantees warm floors throughout the whole building.

"We have extensive expertise in supplying specialised construction components for the high-end aviation sector," says Ronald Kräftner. "We also value the technically simple yet highly effective acoustic ceilings from Variotherm! This is also a very attractive product which meets with our complete satisfaction".



## TECHNOLOGY ModuleStandardCeiling-Classic

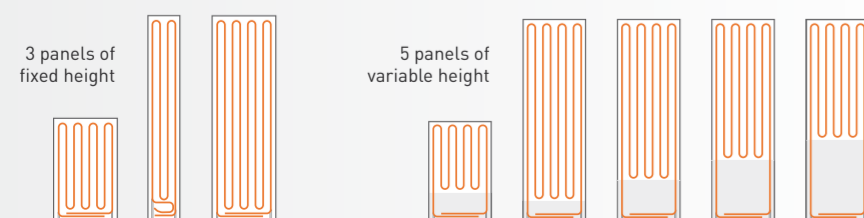
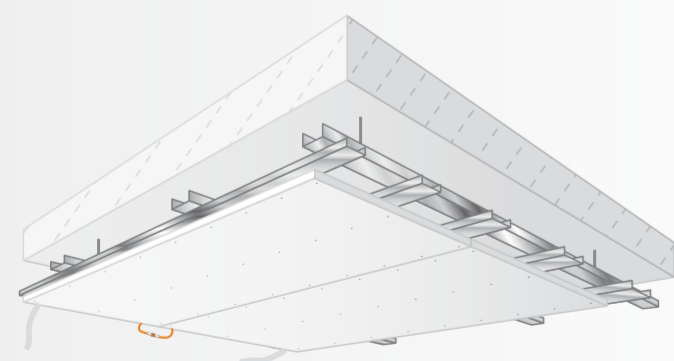

## ModuleStandardCeiling-Acoustic

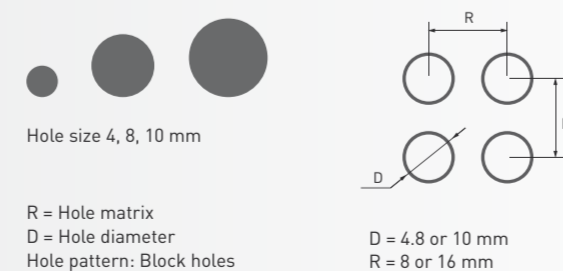
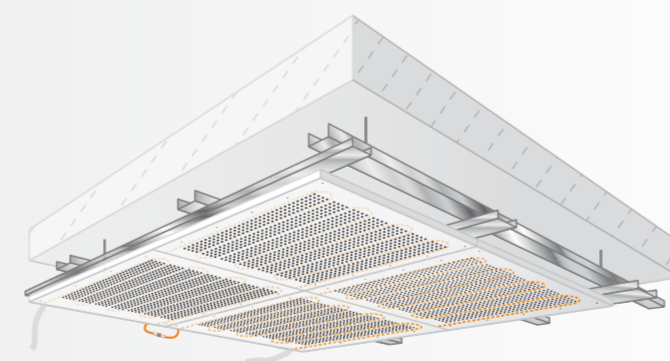

## VarioRoll floor heating

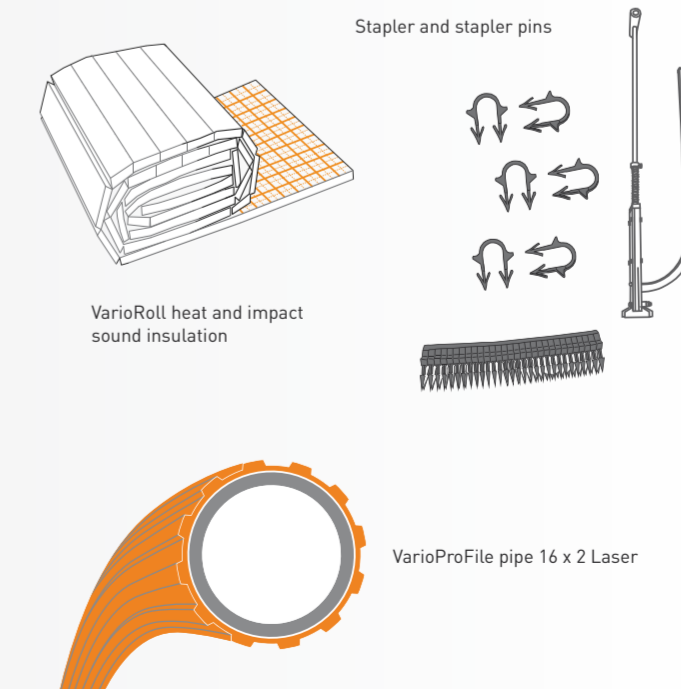
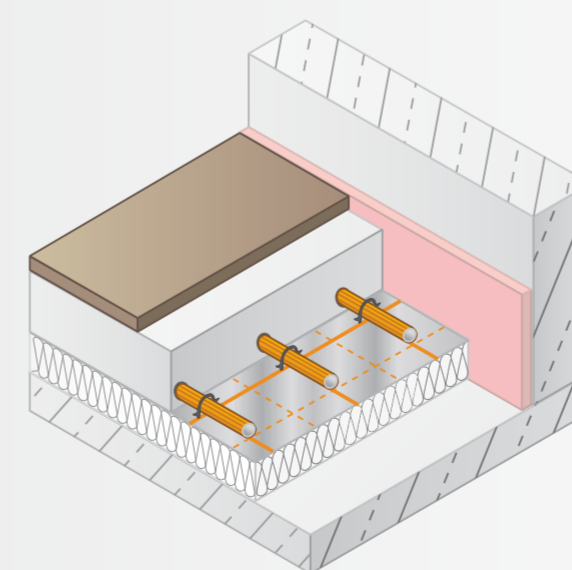

## AMES Aerospace and Mechanical Engineering Services

Planning and construction management  
Architekt DI Joachim Herler  
AT-8051 Thal/Graz

Installer  
Fasching Johann Installations-GmbH  
AT-8650 Kindberg  
[www.ht-fasching.at](http://www.ht-fasching.at)

Variotherm Systems  
115 m<sup>2</sup> MODULE STANDARD CEILING - CLASSIC  
240 m<sup>2</sup> MODULE STANDARD CEILING - ACOUSTIC  
130 m<sup>2</sup> VARIOROLL FLOOR HEATING

# Built for well-being. Forward-thinking.

This is the biggest phase of investment in the successful 34-year history of Variotherm: two new halls at the Leobersdorf plant will offer more space for storage and production in future.

Cool ideas and new products require space to unfold. But the Variotherm family is growing constantly when it comes to the people who bring a breath of fresh air to the company as employees. The expansion of the company headquarters takes account of this and now offers plenty of space for lasting success over the years to come.

Two new halls for storage and production were completed on time before the start of summer. One of the core features of the production site is its milling dust disposal system which is now housed in the new building.

The work on the new buildings presented a real challenge due to the endless cold weather, persistent rainfall and substantial snowfall. The construction professionals from the region worked very efficiently and we would like to express our thanks to them.



### Mobility with e-concept

The new transport logistics system enables up to 6 trucks to be loaded and unloaded at the same time. Access for customers and employees has also been improved. In accordance with Variotherm's sustainability agenda, the vehicle fleet will include environmentally-friendly e-bikes and e-cars in future.



### 1:0 to fun at work

Friends, family and children were able to see the new buildings for themselves during an enjoyable summer party for the entire Variotherm team. The new space was given a fitting opening ceremony in the form of a fast-paced indoor hockey tournament!



### Construction details

- Planning phase: 1 year
- Start of construction: 6 March 2013
- Completion of phase I: July 2013
- New usable hall space: 800m<sup>2</sup>
- New employee parking spaces: 17
- New asphalt areas: approx. 1,500 m<sup>2</sup>

### Participating firms: in accordance with our CSR concepts, we use local suppliers and craftworkers where possible

- Strabag – Wr. Neustadt
- Rosner – Leobersdorf
- Sadler Lichtkuppeln – Oeynhausen
- Tors – Bad Vöslau
- Guardi – Möllersdorf
- Fenster Schir – Leobersdorf
- IBS-Zäune – Bad Vöslau
- KosaPLan – Leobersdorf

### All going to plan!

Stages of construction up to 2015:

- Addition of approx. 200 m<sup>2</sup> of space in the R&D area
- Creating space for the technology competence team
- Spacious kitchen and common room area
- New sanitation areas
- Bright seminar rooms
- Oasis of well-being and ideas
- Expansion of production facilities



# Everything and more

4 x new products from Variotherm to offer everything a professional could wish for: more flexibility, compactness, performance and efficiency!



3 new packaging boxes for 100 m, 300 m and 500 m VarioProFile pipe

## Stable and flexible VarioProFile pipe 11.6x1.5 Laser

- The perfect piping for compact floor heating and EasyFlex wall heating/cooling
- Light and easy to bend
- 100% oxygen and steam diffusion-tight
- Profiled surface (+10%) for optimised heat transfer

## Light and supple Compact filling compound T7

- New colour, no confusion with grey construction materials
- Supple and easy to process
- Low degree of shrinkage
- Machine workable
- Increased pot life, including with higher room temperatures
- Optimised for application of a 2nd layer
- At 20°C room temperature, can already be heated to 40°C after 2 hrs

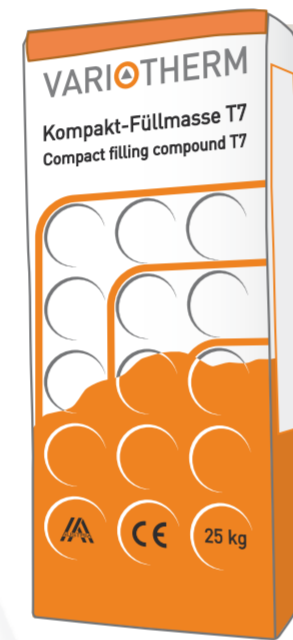

## Secure and high performance Pump distribution station

- Hydraulically perfect structure, genuine injection system
- Low pressure loss
- Shut-off ball valve for rinsing process on the high-pressure side
- Electronic safety thermostat (no bi-metal)
- Wilo Yonos-Para 15/6 high-efficiency pump, already meets the strict regulations of the Ökodesign guidelines (ErP) of 2015
- Depth of only 100mm (incl. thermostat)

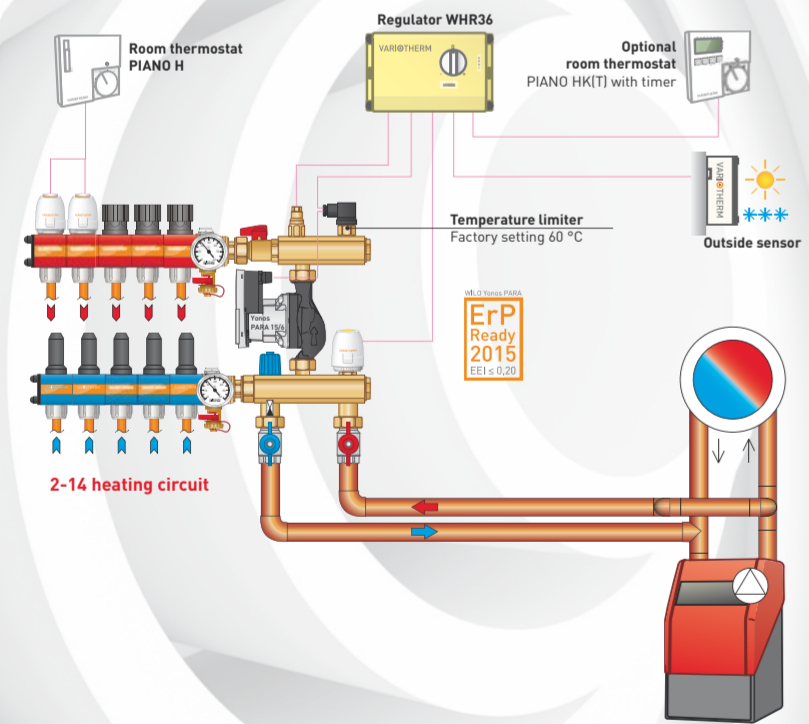

## Small and magnificent Pump micro-station

- Genuine injection system such as PVST
- One device for 1 and 2 heating circuits
- Wilo Yonos-Para 15/6 high-efficiency pump, already meets the strict regulations of the Ökodesign guidelines (ErP) of 2015 [energy efficiency index  $\leq 0.2$ ], very fine tuning of water quantities
- Fill and drain valves for rinsing
- Conversion to operation with actuators possible for panel heating circuits
- Depth of only 100mm

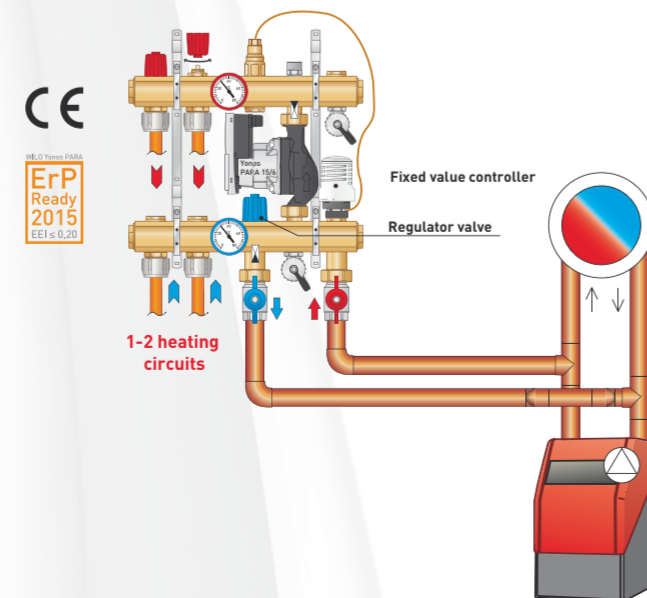

# The freedom troop

75 years of focused practical experience in dealing with people. The Variotherm sales team is undoubtedly the strongest link between Variotherm and its customers and partners.

"Working for the field sales team is a very challenging and demanding job – a profession which involves a great deal of responsibility and which is based on trust from all angles," says Herbert Holzbauer. As the long-standing Sales Manager at Variotherm, he knows what he is talking about. When asked what is the best thing about his job, he answers from the heart: "The freedom".

Many companies have to strive to keep their field sales team as much under control as possible. But Variotherm has adopted a more appreciative and human approach: "I am a big fan of deliberately not controlling exactly how my workers choose to organise their work," says Herbert Holzbauer. "Their job is to contribute to the success of the company. And they are achieving this of their own accord, with distinction. Of course, there is a great deal of trust involved – but I would walk over hot coals for all of my employees. As salesmen, we are used to overcoming obstacles throughout our lives. This requires a troop which sticks together. It's not just about convincing the customer. It is also important to enforce the interests of our customers within the company".

The experienced sales manager is convinced that there is no job more active than working in field sales: "A salesman has to be proactive to bring new impetus to things and developments. At Variotherm, we are very open to suggestions from our employees.

Suggestions made on-site are implemented in a fast and non-bureaucratic manner. This gives rise to lots of new ideas, innovations and products".

The Variotherm products also focus on sustainability. The use of fixed installation systems and systems with a technical service life of over 100 years requires a great deal of confidence in our installation partners. Our relationships with our customers are equally stable and long-lasting. "Many good acquaintances and even genuine friendships have developed over the years. Sales is a very personal and individual field. Every Variotherm salesperson has his own style. And each is successful in its own way," says Holzbauer.

Three sales professionals are responsible for 55% of the overall turnover: Peter Unterrainer is one of the old hands in the business with 16 years of professional experience. His expertise is valued by customers from central and southern Austria. Robert Kissler is no less remarkable with 11 years of experience at Variotherm. He handles the north and east of the country. And the most recent team member with just 3 years of experience is the ambitious and successful Clemens Burgstaller who is responsible for western Austrian and south Bavaria.

The remaining 45 % of turnover is derived from the export business. While Herbert Holzbauer (19 years at Variotherm) handles the markets in Germany, Liechtenstein and Switzerland, Managing Director Alexander Watzek (26 years) addresses customer concerns on the remaining export markets in person.



EXPORT  
DE, LU, CH  
Herbert Holzbauer  
h.holzbauer@variotherm.at

AUSTRIA  
West  
Clemens Burgstaller  
c.burgstaller@variotherm.at

AUSTRIA  
Central-south  
Peter Unterrainer  
p.unterrainer@variotherm.at

AUSTRIA  
North-east  
Robert Kissler  
r.kissler@variotherm.at

EXPORT  
Alexander Watzek  
a.watzek@variotherm.at



# Stay P:UR!

Identifying potential and maintaining a respectful interaction with nature and others is Variotherm's guiding principle when it comes to sustainability. The desire to achieve authenticity is shared by all of the team – and guides the company on its road to success.

"Anyone wishing to pursue an environmentally-friendly lifestyle should start on their own doorstep," according to the employees at Variotherm. As such, they decided to launch a cleaning campaign on their premises. The surprising result: in just 45 minutes, an unbelievable 450 kg (!) of bulky waste had been collected from the area surrounding the company building.



This example alone shows how careless society can be in its use of resources – and how much responsibility a manufacturing company has to protect the environment. "Respect, environmental awareness and sustainability can only be applied from within," says Eva Demuth who is passionately committed to the 'Erfolg mit Fairantwortung' project (success with fair responsibility) implemented by the resPACT association on behalf of the state of Lower Austria. "Genuine conviction and the decision to act with consideration cannot be imposed – a role model effect is required. The Variotherm P:UR team has been launched for this very purpose. When establishing this group, it was important for us that it would not fall to the group leaders to undertake the task but rather to those employees wishing to rethink their own habits of their own accord. In this way, we have already passed numerous important milestones!"

## There are numerous facets to fair responsibility:

### HEALTH...

... starts with an awareness of healthy nutrition. This is why we serve Variotherm smoothies from Weltladen, fruit juices from Bio-Schäfer, healthy fruit and vegetables from AdamahBioHof and fairtrade coffee and organic teas from Sonnentor. In addition to this, it's all about exercise, exercise! As such, our company excursions combine further training with trips out into nature.

### EMPLOYEE PARTICIPATION...

... forms the basis of our human interaction. All of the company's employees are already invited to share their ideas at the quarterly meetings. Theme-specific video evenings, magazines, books and audio CDs also raise employee awareness within the company.

### TEAM SPIRIT...

... is demonstrated by Variotherm employees by their voluntary readiness to donate the rounding differences from their salaries for a whole year. At the end of the year, Variotherm will double the sum collected. The charity to which the sum will be donated will be decided together.

### RECYCLING ...

... is one of the most important issues for the future. The primary waste produced at Variotherm is milled dust which will be recycled in compressed form in the future. Pipe remnants will also be chopped up and 100% recycled.

### ENVIRONMENTAL COMPATIBILITY...

... forms the focal point of research and design. 96,000 euros have been spent on this over the last financial year alone. The results include the new packaging units. Changing the format of the impact sound insulation also means that 24% more material fits into a truck than before. This reduces CO2 emissions. We also use PU adhesives

without toxins and biodegradable packaging film made from sugar cane starch.

### CUSTOMERS...

... receive precisely calculated quantities of materials thanks to the use of special dimensioning software at Variotherm. This also helps to preserve our natural resources.

### SUPPLIERS...

... are visited on a regular basis. We select suppliers which share the Variotherm philosophy and are located in the local area. In the case of our main product, this saves 10 tonnes of aluminium each year.

## Nominated for TRIGOS 2013

TRIGOS is the Austrian award for Corporate Social Responsibility (CSR). Companies are assessed according to their comprehensive commitment to social and ecological issues. The TRIGOS jury places a great deal of importance on whether companies applying to TRIGOS go beyond the implementation of individual measures and also incorporate their social responsibility into their corporate philosophy and strategically apply this across all areas of activity.

Variotherm took part for the second time this year and was nominated twice for the sustainability award – both at the Lower Austria state level and at a national level for Austria as a whole. However the aim of the competition is not about presenting awards. The greatest gain of all is in exchanging ideas with other responsible entrepreneurs and anchoring environmental awareness in society.

